

**BENDIX/KING KRA 405B RADAR ALTIMETER SYSTEM - DESCRIPTION AND OPERATION****1. General**

- A. The section gives the description and operation of the Bendix/King KRA 405B Radar Altimeter System. Airplanes 20800500 and On and Airplanes 208B2000 and On line replaceable units (LRU)'s include, the KRA 405B Radar Altimeter Unit and the Sensor Systems forward and aft radar altimeter antennas. Airplanes 20800365 thru 20800499 and Airplanes 208B0916 thru 208B1999, LRU's include the KRA 405B Radar Altimeter Unit, Audio Generator, forward and aft antennas and a radar altimeter indicator.
- B. For Airplanes 20800500 and On and Airplanes 208B2000 and On the radar altimeter data is shown on each of the two primary flight displays (PFD)'s. For Airplanes 20800365 thru 20800499 and Airplanes 208B0916 thru 208B1999, there is a radar altimeter indicator installed in the left portion of the instrument panel.
- C. For Airplanes 20800365 thru 20800499 and Airplanes 208B0916 thru 208B1999 system description, operational check and troubleshooting procedures, refer to the applicable King Service/Parts Manual found in the List of Publications in front of this manual.
- D. For an overview of the system refer to Figure 1.

**2. Description**

- A. The KRA 405B Radio Altimeter system functions as an accurate source for altitude data during the approach and landing phases of a flight that is shown on each of the two PFD's. The radar altimeter unit has a range of -20 feet to 2,500 feet (-6.1 to 762.0 m). At 0 to 500 feet (0 to 152.40 m) the radar altimeter unit has an accuracy of 3 feet (0.91 m) or, + 3% or - 3%, whichever is greater. At 500 to 2,500 feet (152.40 to 762.0 m), the radar altimeter unit has an accuracy of, + 5% or - 5%.
- B. The KRA 405B Radar Altimeter Unit is installed on the Model 208 / 208B aft avionics shelves at the following locations:
  - (1) For Model 208 airplanes:
    - (a) KRA-405B - FS 336.22, RBL 10.22.
  - (2) For Model 208B airplanes:
    - (a) KRA-405B - FS 384.22, RBL 10.22.
- C. The KRA 405B Radio Altimeter system has a forward (transmit) and an aft (receive) antenna. The antennas are installed as follows:
  - (1) For the Model 208 antennas:
    - (a) Forward antenna - FS 333.39, RBL 7.21.
    - (b) Aft antenna - FS355.89, RBL 5.40.
  - (2) For the Model 208B antennas:
    - (a) Forward antenna - FS 381.39, RBL 7.21.
    - (b) Aft antenna - FS403.89, RBL 5.40.

**3. Operation**

- A. KRA 405B KRA 405B Radar Altimeter Unit Unit is given 28Vdc electrical power through the RADIO ALT circuit breaker found on the Avionics circuit breaker panel. The Radar Altimeter Unit altitude data is created by the radar altimeter unit generating a 4.3 GHz RF signal from its transmitting antenna, that is installed on the bottom of the aircraft. The generated signal reflects off of the ground and the reflected signal is received by a receive antenna mounted near the transmit antenna. The time delay is used to calculate the distance the aircraft is from the ground. This data is sent to the G1000 integrated avionics system through an ARINC 429 bus to the Garmin 63W integrated avionics unit GIA No.1. The data is shown on each of the two PFD's for use by the pilot. In addition to the above, when the G1000 system, using the altitude information from the KRA 405B, determines that the aircraft is approaching the ground, the altitude strip on each of the two PFD's are covered over with a brown background texture similar to the attitude background texture, to indicate to the pilot that the airplane is nearing the ground.

Figure 1 : Sheet 1 : Bendix/King KRA 405B Radio Altimeter System

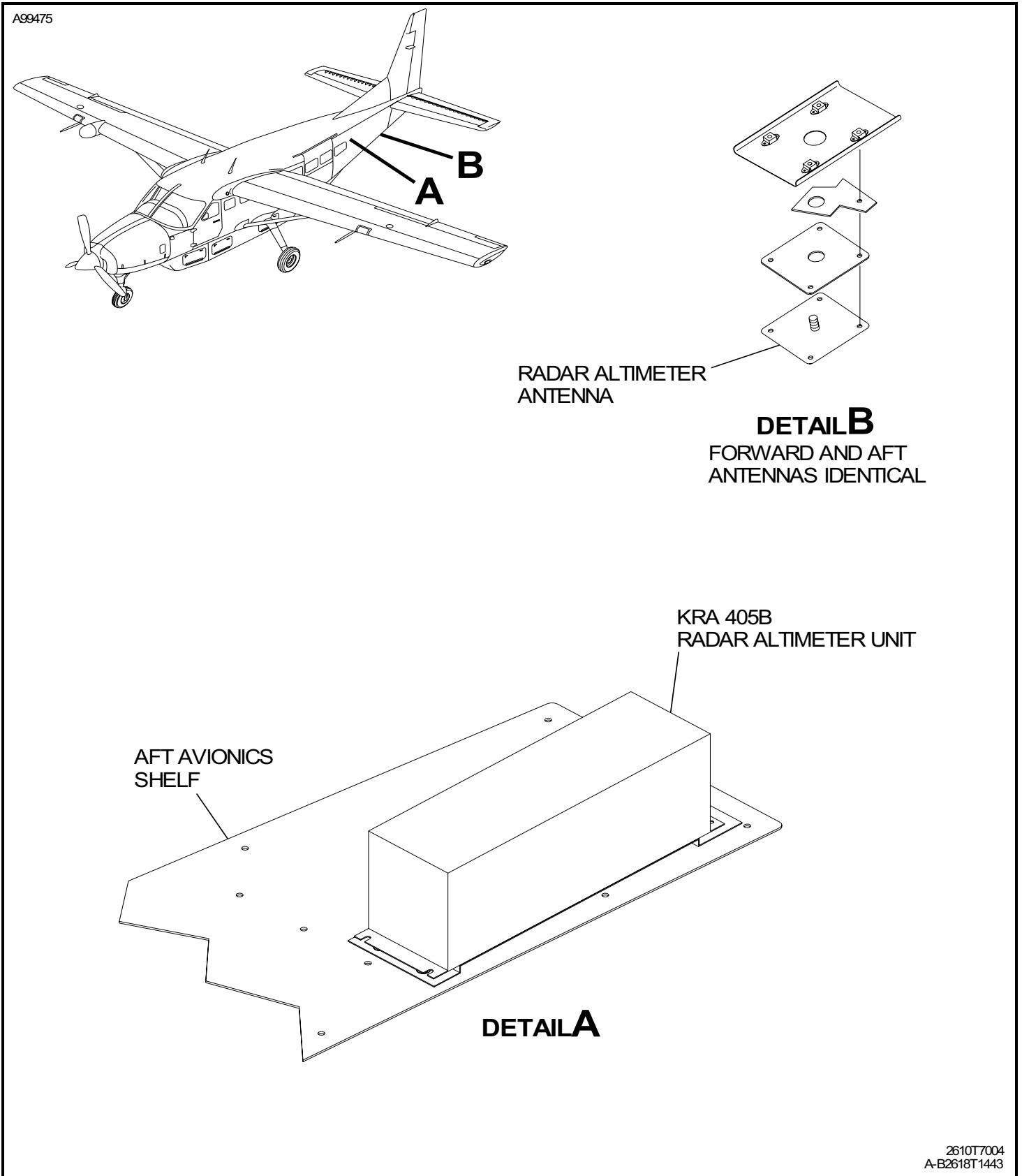

2610T7004  
A-B2618T1443